

FOILER ET Automatic hot-air welding machine

Automatic Overlap Welding Machine

- For overlap welding of industrial fabrics (PVC, PP, PE, etc...)
- Welding seam width 20 or 30 mm

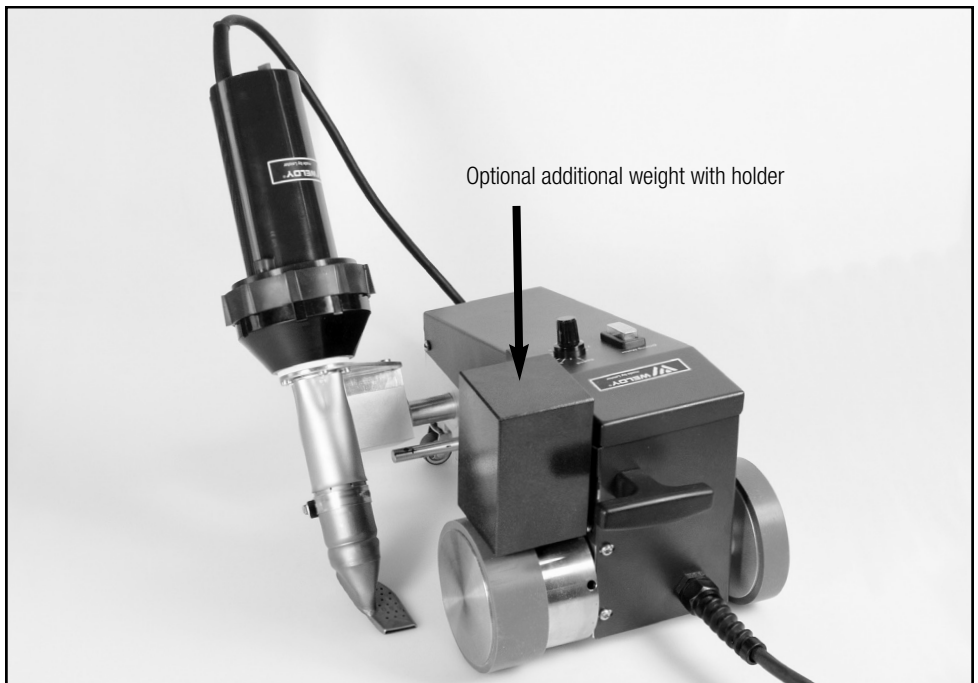

Please read operating instructions carefully before use and keep it for further reference.

TECHSPANGROUP

Australia:
Tel. 1-800 148 791
Fax: 1-800 148 799
Email. info@weldy.com.au
Web. www.weldy.com.au

New Zealand:
Tel. 0800 603 603
Fax: (09) 827 6596
Email. info@weldy.co.nz
Web. www.weldy.co.nz



Warning



Danger! Unplug the tool before opening it, as live components and connections are exposed.



Incorrect use of hot air tools can present a **fire and explosion hazard**, particularly in the proximity of flammable materials and explosive gases.



Danger of getting burned! Do not touch the end of the heater tube and nozzle when they are hot. Let the tool cool down. Do not point the hot air flow in the direction of people or animals.



Connect tool to a **receptacle with protective earth terminal**. Any disconnection of the protective conductor in or outside the tool is dangerous!

Use line/mains extension cables with protective earth/ground conductor and adequate cross sectional area only!



Caution



The **rated voltage** stated on the tool must correspond with the mains voltage. In the case of a **power cut**, the **drive switch (11)** and **air blower switch (13)** have to be set to **0**.



For personal protection, we strongly recommend the tool to be connected to an **RCCB** (Residual Current Circuit Breaker) before using it on construction sites.



The tool must be operated **under supervision**.

Heat can ignite flammable materials which are not in view.

The machine may only be used by **qualified specialists** or under their supervision. Children are not authorized to use this machine.



Protect the tool **from damp and wet**.

Technical data

Voltage	V~	230
Frequency	Hz	50 / 60
Power consumption	W	1700
Temperature	°C	20 – 650
Air flow (20 °C)	l/min.	200 – 270
Drive speed	m/min.	1.0 – 7.5
Noise emission level	L _{pA} (dB)	76
Dimensions	mm	445 × 276 × 280
Weight	kg	10.8
Protection class I		

Tool description

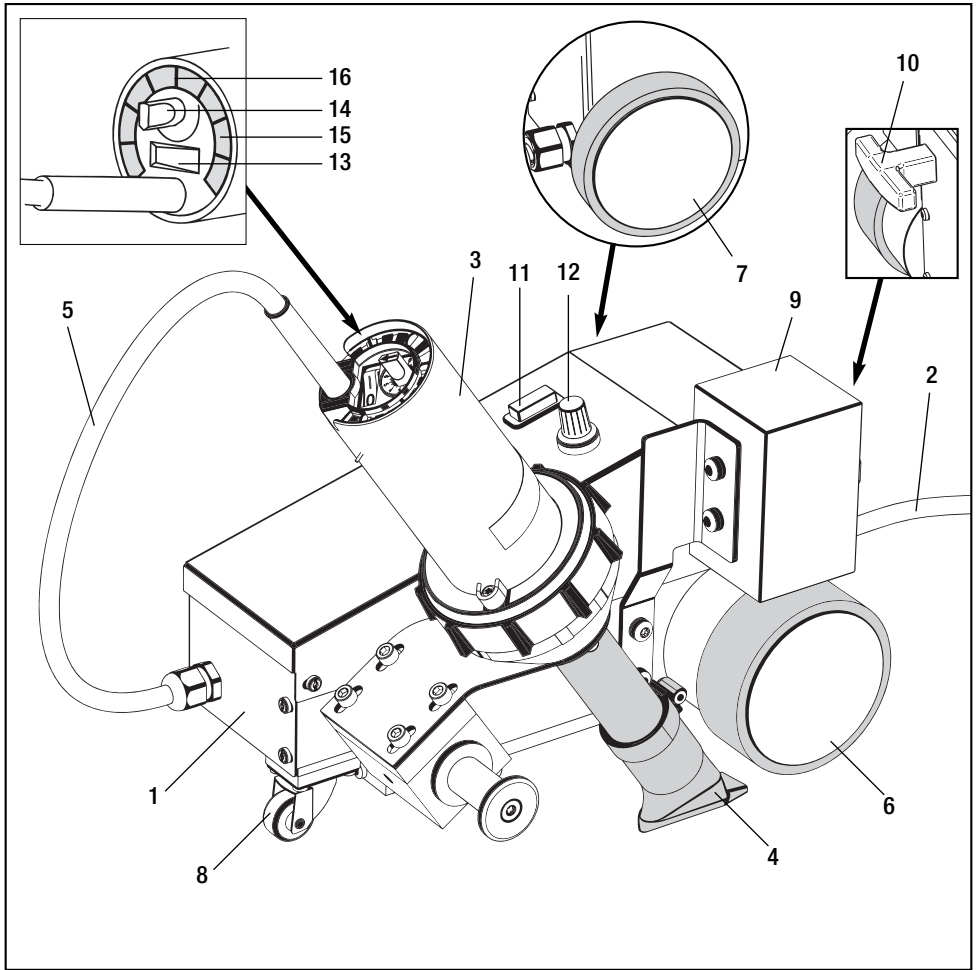

Main components

- 1 Housing/chassis
- 2 Power supply cord
- 3 Hot air blower
- 4 Welding nozzle
- 5 Connection cable
- 6 Drive/pressure roller
- 7 Drive roller
- 8 Steering roller
- 9 Additional weight (optional)
- 10 Carrying handle

Operating components

- 11 Drive switch
- 12 Potentiometer for welding speed
- 13 Air blower switch
- 14 Potentiometer for temperature adjustment
- 15 Air filter
- 16 Air slide

Putting into Operation

Observe the mains voltage

- The power source voltage must correspond with the value given on the nameplate. Extension cords must have a conductor cross section of $3 \times 1.5 \text{ mm}^2 \text{ min.}$

Switching Heating On:

- Set **switch (13)** position **I**. Adjust air flow as required with **air slide (16)**. Adjust temperature as required with the **potentiometer (14)**. The heat-up period is approx. 5 minutes.

Switching Heating Off:

- Turn the **potentiometer 14** to position **0** in order to cool the tool down. When the tool has cooled down, set **switch (13)** to **0**.

Operating condition

- Check the **welding nozzle (4)** basic setting (Detail A and Detail B).
- Connect the tool to the line/mains. The line/mains voltage must correspond with the voltage rating stated on the tool.

Detail A

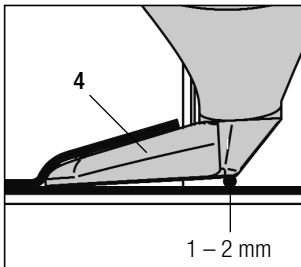

Detail B

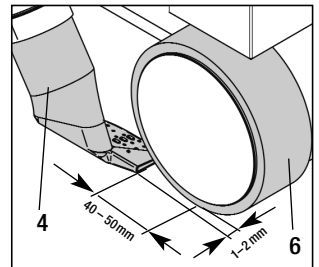

Operating Instructions

- Perform a test welding according to the welding instructions of the material manufacturer and national standards or guidelines. Check the test welding. Adapt welding temperature (welding parameters) as required.

Tool positioning

- Swivel **hot air blower (3)** up to the stop.
- Position the automatic welding machine on the overlap of the material to be welded. The outside edge of **drive/pressure roller (6)** must line up with the overlap edge of the material to be welded.

Welding parameters

- Set **potentiometer for welding speed (12)** to required value.
- Set **air blower switch (13)** to position **I**. Set temperature and air flow to required values and heat up for about 5 minutes.
- The contact pressure is effected through the weight of automatic hot air welding machine itself. Use additional weight accessory as required (see assembly of additional weight, page 5).

Welding procedure

- Swivel **hot air blower (3)** down to the stop and at the same time turn on the **drive switch (11)** (the welding process starts).
- Supervise welding process. As necessary correct welding speed with **potentiometer (12)**. Lead the automatic welding machine by its chassis along the length of the overlap.
- When welding has finished, swing up **hot air blower (3)** to the stop.
- Switch **drive switch (11)** off.
- After completing welding work, turn **potentiometer 14** to **0**, so that the **hot air blower (3)** cools down. Then turn off the **air blower switch (13)**.
- Disconnect the tool from the line/mains.

Additional weight

Assembly of additional weight

- Fasten **additional weight holder (21)** to the FOILER ET machine with **spring washer (22)** and **lens head screw (23)**.
- Fasten **additional weight (9)** to **additional weight holder (21)** with **spring washer (24)** and **lens head screw (25)**.

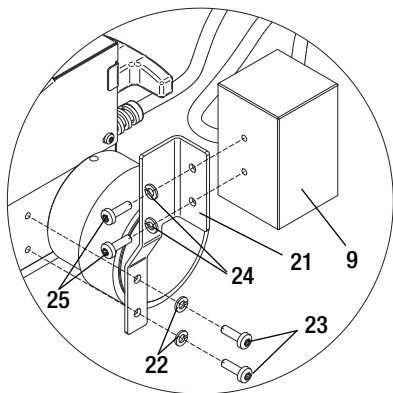

- 9 Additional weight
- 21 Additional weight holder
- 22 Spring washer
- 23 Lens head screw M6 × 20
- 24 Spring washer
- 25 Lens head screw M6 × 20

Accessories

- Only Weldy accessories must be used.
- Additional weight with holder

Training

- Leister Technologies Ltd. and their authorised service centres offer welding courses.

Maintenance, Service and Repair

- For safe and efficient working always keep the unit and its ventilation slots clean.
- Clean **welding nozzle (4)** with wire brush.
- Check **line/mains connection (2)** and plug for electrical and mechanical damage.
- If the unit should fail despite the care taken in manufacture and testing, repair should be carried out by an authorized customer service centre using original spare parts.

Warranty

- For this tool, we generally provide a warranty of six (6) months from the date of purchase (verified by invoice or delivery document). Damage that has occurred will be corrected by replacement or repair. Heating elements are excluded from this warranty.
- Additional claims shall be excluded, subject to statutory regulations.
- Damage caused by normal wear, overloading or improper handling is excluded from the warranty.
- Warranty claims will be rejected for tools that have been altered or changed by the purchaser.

Technical data and specifications are subject to change without prior notice.

Your authorized service centre is: